

Cerro Tololo Inter-American Observatory

CHIRON
instrument description
I. Optics and mechanics

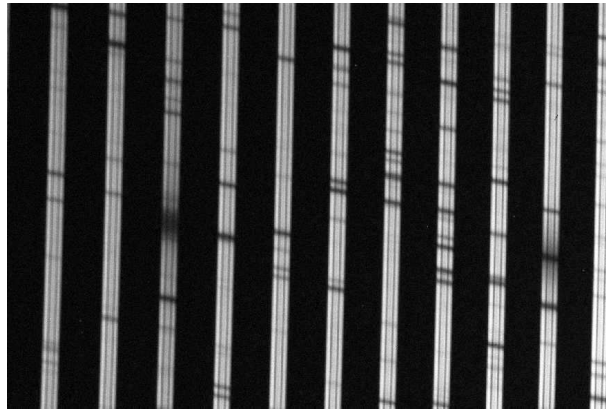

A. Tokovinin
Version 3. July 11, 2012 (chiron.pdf)

Contents

| | | |
|----------|--|-----------|
| 1 | Overview | 3 |
| 2 | Fiber feed | 4 |
| 2.1 | Telescope interface | 4 |
| 2.2 | Front-End Module (FEM) | 4 |
| 2.3 | Comparison lamps | 7 |
| 2.4 | Main fiber | 7 |
| 2.5 | Acquisition and guiding | 8 |
| 3 | CHIRON spectrometer: optics | 9 |
| 3.1 | Optical design | 9 |
| 3.2 | Echelle grating and prism | 10 |
| 3.3 | The APO camera | 11 |
| 3.4 | Image slicer | 12 |
| 3.5 | Fore-Optics Box (FOB) and viewer | 13 |
| 3.6 | Iodine cell | 14 |
| 3.7 | Exposure-meter feed | 14 |
| 3.8 | Optical transmission | 15 |
| 4 | Mechanical design of CHIRON | 16 |
| 4.1 | ISS and OSS | 16 |
| 4.2 | Enclosure | 17 |
| 4.3 | Dewar attachment | 19 |
| 4.4 | APO mount and focusing | 20 |
| 4.5 | Prism mount | 21 |
| 4.6 | Echelle enclosure | 21 |
| 4.7 | Collimator focus assembly (CFA) | 23 |
| 4.8 | Collimator and fold mounts | 24 |
| 4.9 | Iodine cell and its container | 25 |
| 4.10 | Hartmann mask | 26 |

1 Overview

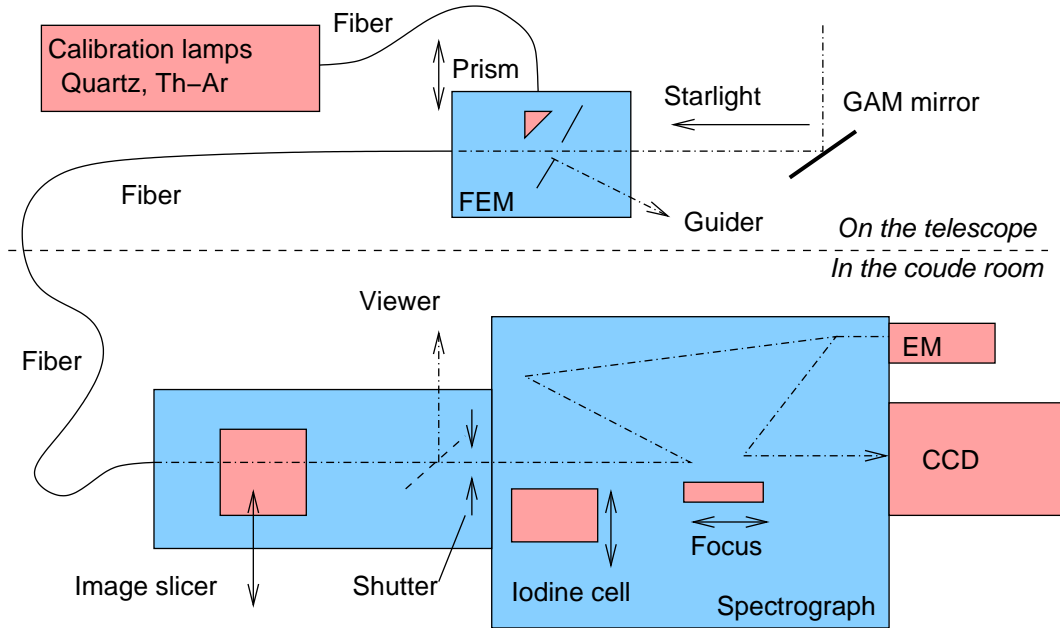

Figure 1: Light path in CHIRON, from the telescope to the CCD. Elements under user control are pink-colored.

CHIRON is a high-resolution fiber-fed echelle spectrometer installed at the CTIO 1.5-m telescope. It can record multi-order echelle spectra of single objects (stars) with spectral resolution up to $R = 80\,000$, 3 pixels per resolution element. The spectral format on the detector is fixed, covering the wavelength range from 4160\AA to 8700\AA without gaps.

Figure 1 shows main elements of CHIRON from the user perspective. We follow the path of starlight, directed towards the fiber front-end module (FEM) by a diagonal mirror located in the telescope GAM (at certain position of the pickup arm). The star image is focused on a mirror with a hole; most of the light goes into the fiber, the remaining halo is reflected towards the acquisition/guiding camera. A small prism can be placed behind the mirror to feed calibration light (quartz or Th-Ar lamps) to the spectrometer.

The spectrometer is located on the coude room. The light beam emerging from the fiber can be re-shaped into a slit-like image by the *image slicer*, to increase spectral resolution without light loss. The slicer can be moved out of the way to work with bare fiber image (with spectral resolution decreased to $R \approx 25\,000$) or to mask the fiber by slits (increase resolution at the expense of light loss). A viewer with manually-activated mirror is used only for troubleshooting to see the sliced image. Other user-controlled elements are the shutter, iodine cell which can be placed in or out of the beam, and the focusing stage. The CCD is operated by a GUI-driven data-acquisition program. About 1% of light in the 500–600 nm range is directed through optical fiber to the photo-multiplier of the Exposure Meter (EM).

CHIRON is designed to be very stable, its internal environment is maintained at constant temper-

ature. Opening the spectrometer or any other intervention or manipulation are **strictly prohibited**.

2 Fiber feed

2.1 Telescope interface

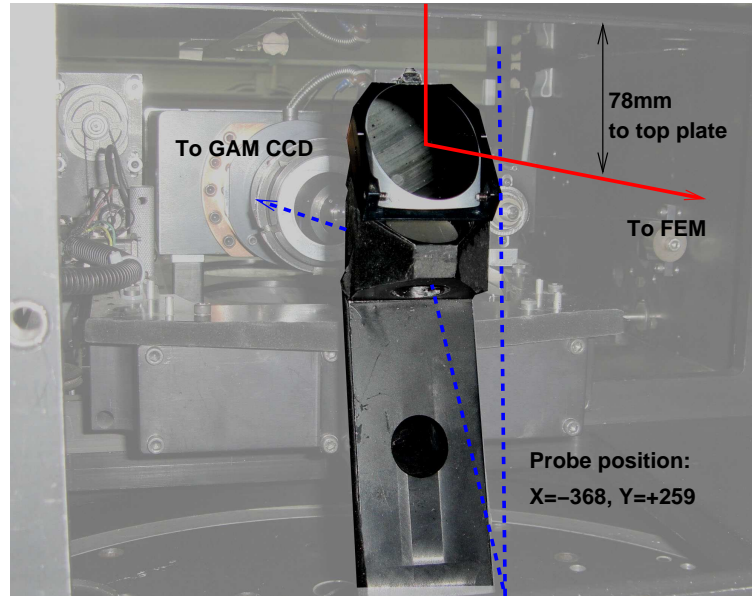

Figure 2: M1 mirror attached to the GAM probe.

The Guiding and Acquisition Module (GAM) of the 1.5-m telescope is normally used for offset guiding. It has been modified by adding a piggy-back elliptical mirror M1 on top of the guide probe arm (Fig. 2). Positioning this probe at the center of the field ($X=-268$, $Y=+259$) makes M1 to intercept the on-axis beam without vignetting and to direct it sideways, to the FEM which is attached to the GAM hatch door. The optical axis of the beam deflected by M1 is at 78 mm below the lower surface of the GAM top plate. Normal operation of the probe is not perturbed, it captures the field at a fixed offset and, if we are lucky to find guide stars there, the standard guiding is possible. The object would be centered in the GAM-camera field if we set $Y=-96$, but then FEM receives no light.

2.2 Front-End Module (FEM)

Figure 3 shows the FEM. When it is attached to the GAM, the space is restricted from all sides. To remove the FEM, loosen the 4 M4 screws, turn the FEM anti-clockwise and pull it away, leaving the screws in place. **Do not disconnect fibers and cables!** Be careful not to damage the cables and the optical fiber. Installation – in the reverse order. The FEM is permanently installed on the telescope, but any repair or trouble-shooting require its removal because the access is difficult.

The main components of FEM are shown in Fig. 4, the optical elements are listed in Table 1. The incoming beam is focused on the concave mirror M2 with two holes in it, one for the star and another,

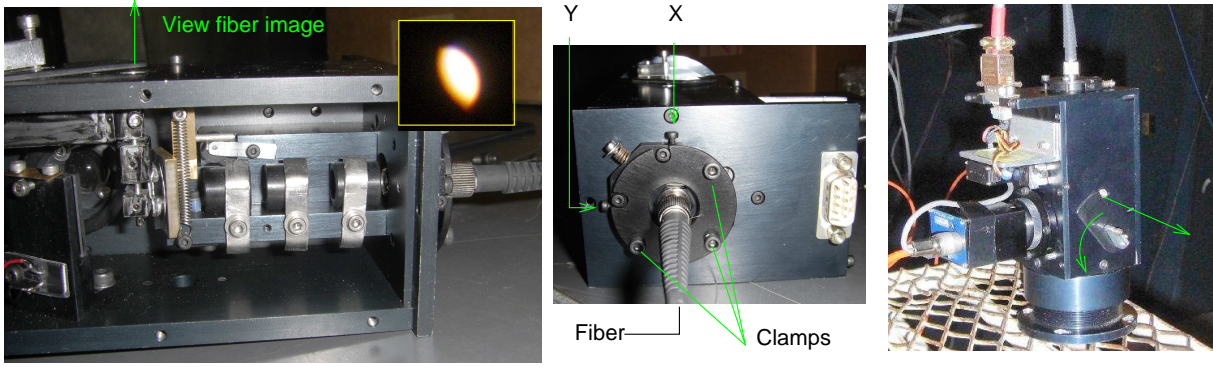

Figure 3: FEM. Left: box opened, alignment optics in place. The insert shows fiber image in mis-aligned condition. Center: fiber alignment screws. Right: FEM detached during alignment/service. The green arrows show where to look during fiber alignment.

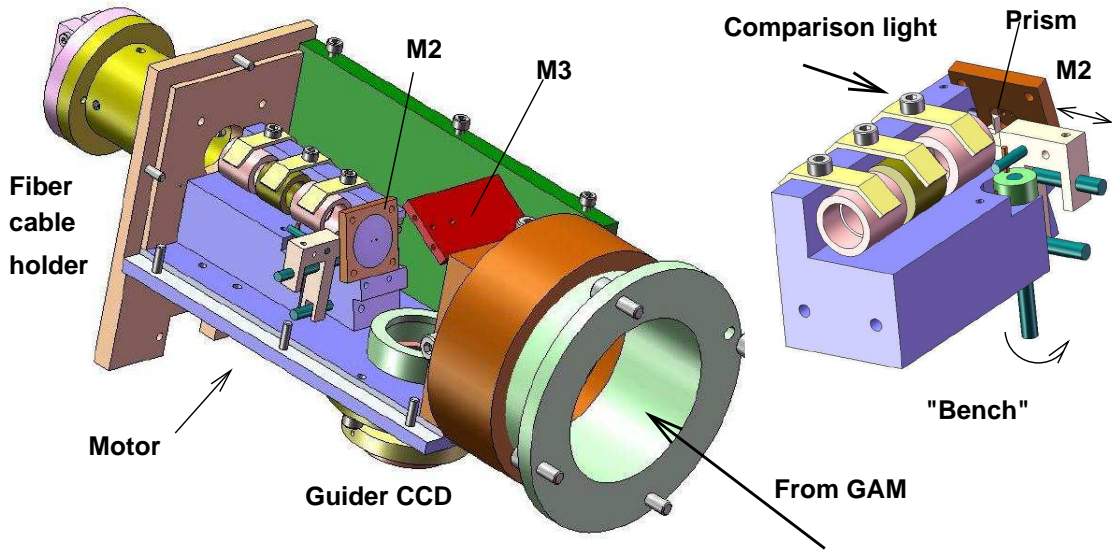

Figure 4: Schematic representation of the mechanical design of the front-end module. The fiber connector has been changed.

larger – for the sky (not used). The light which goes through the central hole is transformed from $F/7.5$ to $F/5$ by a pair of small lenses and is injected into the fiber with a core diameter 100 micron.

The co-alignment between the hole and the fiber is very important. To check it easily, an auxiliary optics (a small mirror and a strong eyepiece) can be lowered in front of M2 (green arrows in Fig. 3). The back-end of the fiber is illuminated (insert the viewer mirror in the FOB, replace eyepiece with a flashlight), the image of its front end can be seen through the hole in the FEM sidewall. Un-clamp the 3 M3 screws of the fiber connector, apply tiny corrections to the X,Y screws (M2). When the fiber is mis-aligned, the image is not round (see the insert). Center the fiber in the hole (get round

image), then firmly clamp the fiber connector and re-check the alignment. Do not forget to retract the auxiliary optics after the alignment check!

The light which does not pass through the hole is reflected by M2, then directed by a flat mirror M3 to the optics of the guider. The 3x reduced image of the field (i.e. of M2) is formed on the CCD camera GC650 from Prosilica. The digital signal is sent via Ethernet cable to the guiding PC (see below).

Table 1: Optical components of FEM

| Element | Vendor, part number |
|-------------------|--|
| M1 mirror | EO M32-134 38.1x53.87mm ell. enh. Al |
| M3 mirror | EO M45-728 20x20 mirror enh. Al |
| Relay lens L1 | EO M47-653 ACH-9x18-VIS0 |
| Relay lens L2 | EO M47-652 ACH-9x12-VIS0 |
| Guider GL | EO M47-638 ACH-25x60-VIS0 |
| Guider GL2a,b | EO M47-665 ACH-12.5x40-VIS0, two |
| Prism | EO A32-525 Right angle 2-mm prism 45° uncoated |
| Fiber patch cable | TL M28L02, 400 μ m, $L = 2$ m |

EO – Edmund Optics; TL – Thor Labs

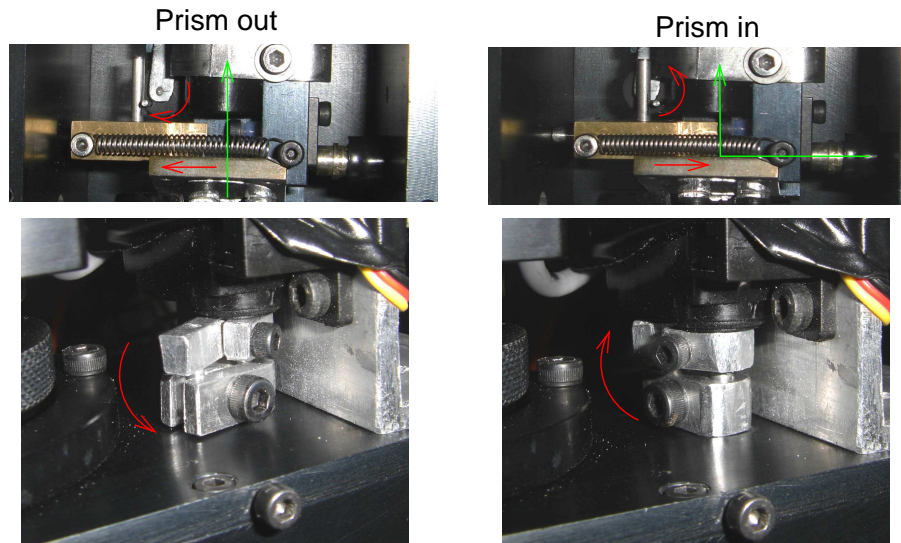

Figure 5: Operation of the comparison-light prism. The upper pictures show the prism holder, cam, and light path as can be seen in the opened FEM box. The lower pictures show corresponding motor positions on the lower FEM wall.

The light of the comparison lamps is brought into FEM by a fiber. It is directed into the main fiber by moving a small (2-mm) prism which slides behind M2. The prism is pushed by a cam mechanism with a finger which, in turn, is actuated by a small servo motor HS-85 from Hitek (Fig. 5).

2.3 Comparison lamps

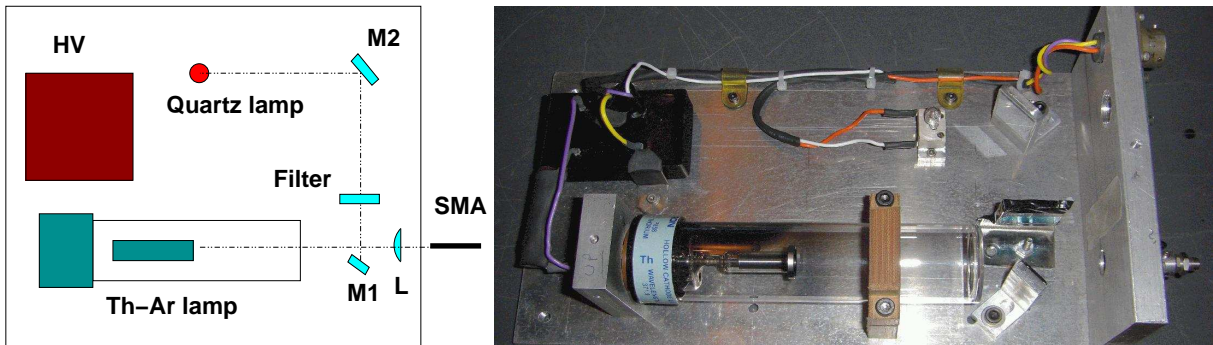

Figure 6: Optical scheme and picture of the Light Box.

The “light box” contains the thorium-argon spectral lamp (P858A 1.5in HCL with Argon fill from Delta Scientific Lab Prods. Ltd) and the quartz lamp. The SMA connector of the fiber (core diameter 0.4 mm) receives the image of the thorium cathode formed by a $F = 18$ mm lens (it is aligned with the fiber). The lamp is powered by 500 V voltage produced by the DC/DC converter in the light box (EMCO F05, 0-12V input, 0-500V/20mA output), while a 50 kOhm/12W resistor in series limits its current to 8 ma. The quartz lamp (6V, 20W) is also co-aligned with the fiber, so its light is very bright. The 4-mm thick BG38 color-balance green filter is installed to equalize the intensity between red and blue wavelengths. A small fraction of the quartz-lamp light by-passes the filter to provide calibration at long wavelengths.

The electronics box contains a simple pulse generator for controlling the prism servo motor in the FEM, relays for switching the spectral lamps, logic, and the power supplies (12V and 5V). The DC/DC converter for the spectral lamp is powered by 12V. The power switch on this box activates all the electronics. The control of the lamps, motor, and LED done by the data-taking software.

2.4 Main fiber

The fiber that brings the star light to CHIRON is multi-mode with $100 \mu\text{m}$ core diameter with FC connectors at both ends. Originally, we used a 15-m fiber type FPB1001120140 from Polymicro. According to our measurements, for $F/5$ input and output beams the transmission was around 0.70. Major part of the light loss was caused by the focal-ratio degradation (FRD), as the intrinsic transmission is > 0.90 .

In February 2012, a new 20-m fiber with octagonal core was installed, in hope to improve the light scrambling. It has a better transmission of 0.57 at $F/5$. Unfortunately, a small (few percent) fraction of light was scattered into fiber cladding and caused unwanted halo around spectral lines. Another octagonal fiber without scattering was installed on May 28, 2012. It is made by CeramOptec, part No. FC2/OCT100/660A/BPGS/20M/Yale. The fiber is NCC from Optran, with $100 \mu\text{m}$ octagonal core, $660 \mu\text{m}$ round cladding, acrylate jacket, length 20 m, numerical aperture 0.22 ± 0.02 . The transmission of Fiber#2 measured by J. Spronck with $F/5$ input and output at 514 nm is about 0.87. The light scattered in the cladding is $< 2 \cdot 10^{-5}$.

2.5 Acquisition and guiding

The guiding camera is GC650 from Prosilica. It has 659x493 square pixels, pixel size 7.4 micron (0.38 arcsec on the sky), field of view 3 arcmin. diameter. The signal depth is 14 bits (4096 counts). Minimum exposure time is 0.000001s (10 microseconds). The camera is powered by +12 V from FEM. Its digital signal is transmitted by a dedicated Ethernet cable to the guiding PC which is rack-mounted in the computer room. This PC runs under Linux, its name is `ctioxb`, fixed IP address: 139.229.12.62. The standard `PCguider` program runs on this computer.

3 CHIRON spectrometer: optics

3.1 Optical design

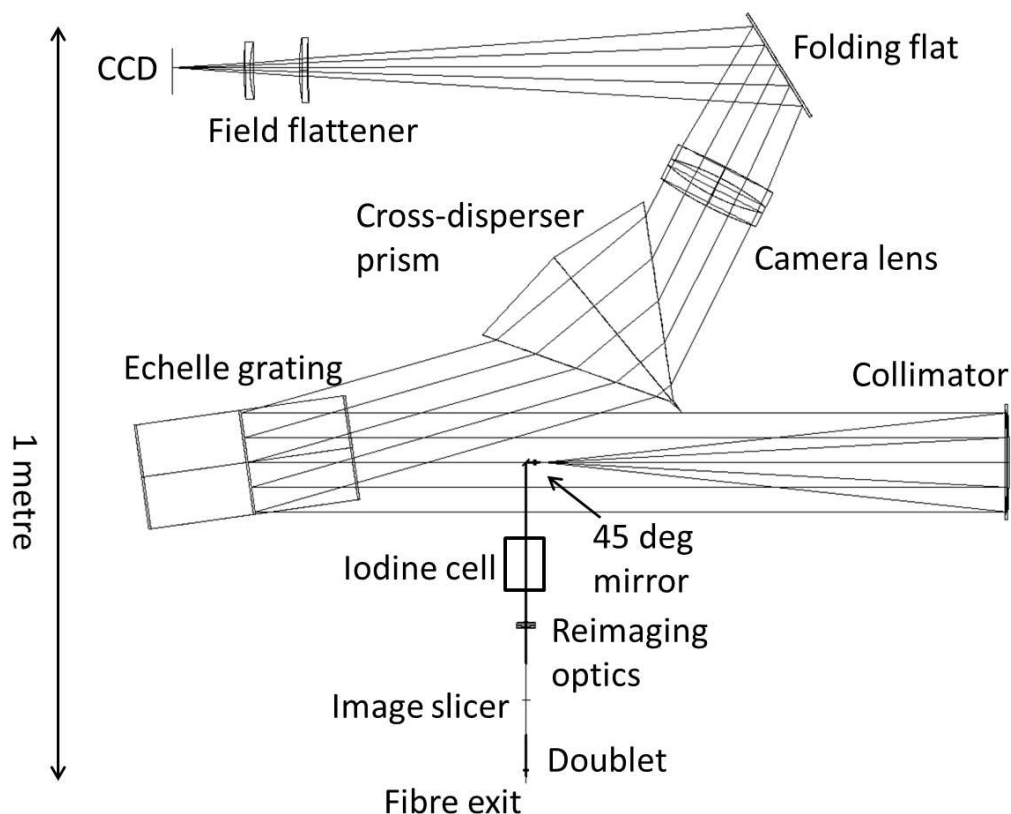

Figure 7: Optical layout of CHIRON.

Table 2: Optical elements of CHIRON

| Function | Element, parameters |
|---------------------|---|
| Main dispersion | Echelle 31.6gr/mm, blaze 63.9°, 260x130mm |
| Cross-dispersion | LF7 prism, apex angle 62°, side 260mm height 160mm |
| Collimator | On-axis parabolic mirror $F = 610$ mm, $D = 150$ mm |
| Camera | APO-140 apochromat & flattener $F = 1005$ mm $D = 140$ mm |
| Folding flat mirror | $D = 150$ mm, Edmund Optics, custom coated |
| Detector | 4096×4096 pixels of 15 μm size |

Main optical elements of CHIRON are listed in Table 2. The incident and reflected beams are separated by tilting the echelle grating perpendicular to the incidence plane by $\gamma = 5.5^\circ$. CHIRON is designed for a 4K CCD with 15 μm pixels. The spectral format is shown in Fig. 8. The orders

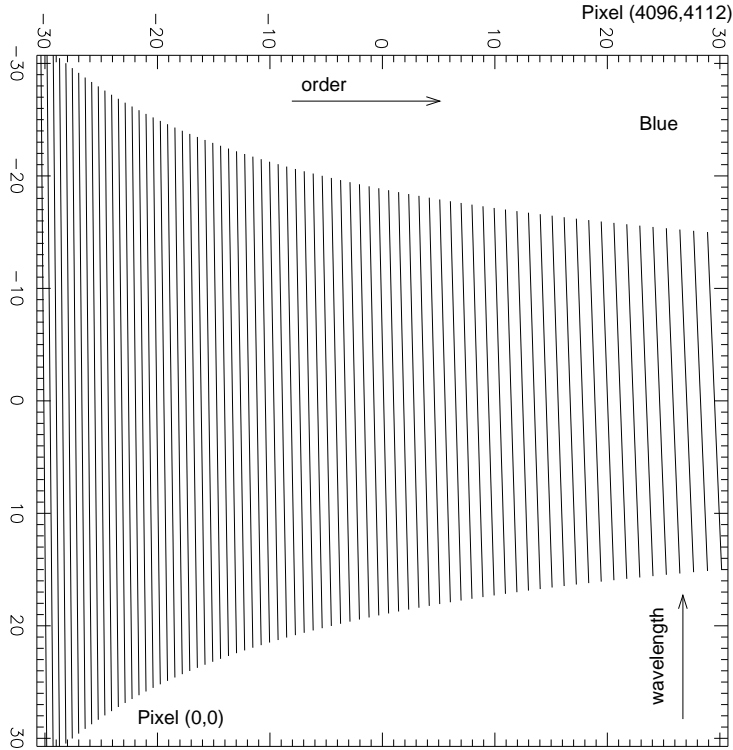

Figure 8: Spectral format of CHIRON covering the range 415–870 nm. The scale on the detector is in mm. Each line covers the free spectral range (FSR) in one order. The rightmost is order 135 (414–418 nm), the left line is order 65 (864–877 nm). The detector center corresponds to $\lambda = 519$ nm.

are slightly curved due to prism dispersion. The line tilt of 24° produced by finite γ is corrected by counter-rotating the image slicer.

3.2 Echelle grating and prism

CHIRON uses an R2 echelle grating as its main dispersion element. In 2012, an old large echelle was replaced by a smaller new grating with higher reflectance (enhanced silver coating). It was procured from Richardson Labs/Newport: 31.6 lines/mm, nominal blaze angle of 63.9° , Zerodur substrate of 135x265x45mm. The ruled area is 130x260mm. The measured efficiency at blaze peak at $\lambda = 514$ nm is 82%. The beam is slightly vignetted by the grating.

The new grating has no ghosts in the cross-dispersion direction. Its ghosts along the dispersion are weak, $< 10^{-4}$ intensity (no good measures are available).

The grating is housed in a vacuum enclosure. Light goes twice through the enclosure window. The window is made of BK7 glass with a 1.5° wedge to avoid reflections. Nominal surface quality $\lambda/4$, with < 4 fringes power. Reflection losses at 4 surfaces are minimized by sol-gel coating on the window ($R < 0.25\%$ per surface at 500 nm). Double reflection from the window produces a parasite feature in the blue part of the spectrum which is mostly outside the free spectral range. The product of wavelength and order $m\lambda$ is 565775\AA . It changes slightly (by 10^{-4}) with wavelength because of the dispersion of the wedged echelle window (it changes γ).

The prism was made by the TORC company in Tucson out of LF7 blank. Inhomogeneity of the

refractive index produces some aberration, despite an attempt to correct them by manual retouching. The prism was sol-gel-coated in January 2012 to optimize transmission at 500 nm and at 54° incidence angle ($R < 0.6\%$). The internal glass transmission averaged over the beam is 98%.

3.3 The APO camera

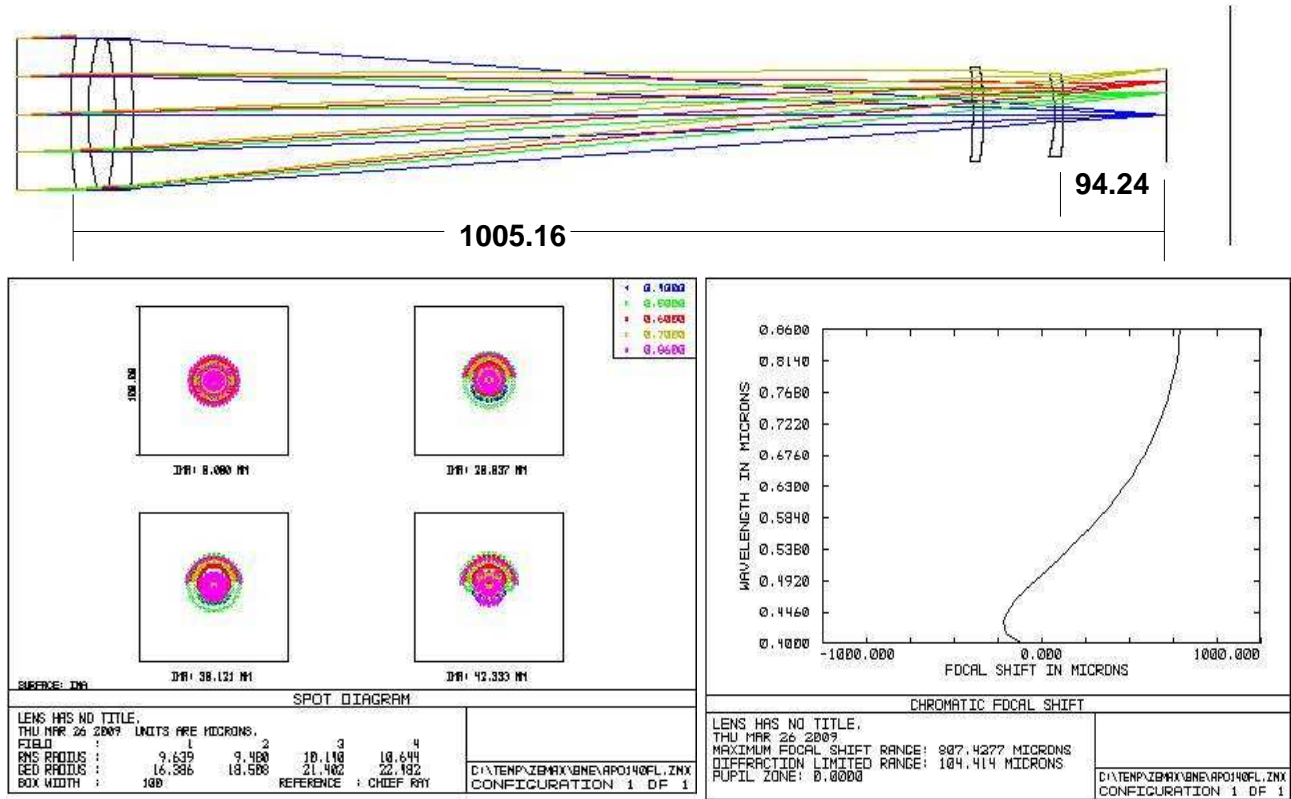

Figure 9: The APO-140 with field flattener. Layout and some dimensions (top), spot diagrams (left, box side 100 μm) and focus dependence on wavelength (right).

The camera is a commercial triplet lens APO-140 produced by Telescope Engineering Company (TEC, <http://www.telscopengineering.com>). This oil-spaced triplet lens has light diameter of 140 mm. The focal length with a 2-element field flattener is 1012 mm. The first-lens-to-detector distance is 1005.2 mm, the back distance is 94.2 mm. TEC has kindly provided the optical prescription, allowing us to evaluate the performance of the triplet lens. As shown in Fig. 9, the spot diagrams fit within 50 μm over the whole field of 42 mm radius (or 60x60 mm square), the maximum admitted by the flattener. The major residual aberration is chromatic defocus, so the lens is diffraction-limited at any given wavelength. The triplet and flattener lenses have broad-band anti-reflection (AR) coatings, with a typical loss of 0.25% per surface.

3.4 Image slicer

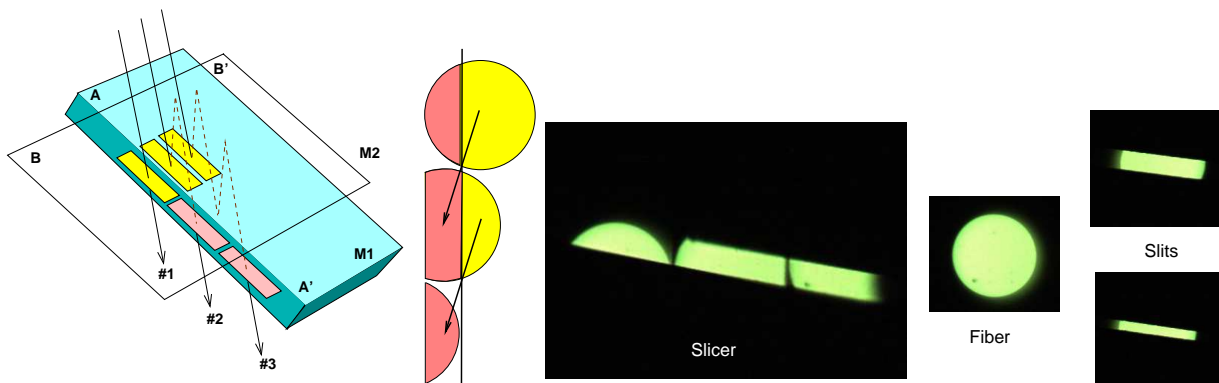

Figure 10: **Left:** optical concept of the reflective Bowen-Walraven image slicer. **Right:** images of the “slit” as seen through the viewer, with fiber illuminated by the quartz lamp. The position of the translation stage defines whether the fiber is sliced, transmitted unchanged, or masked by one of the slits.

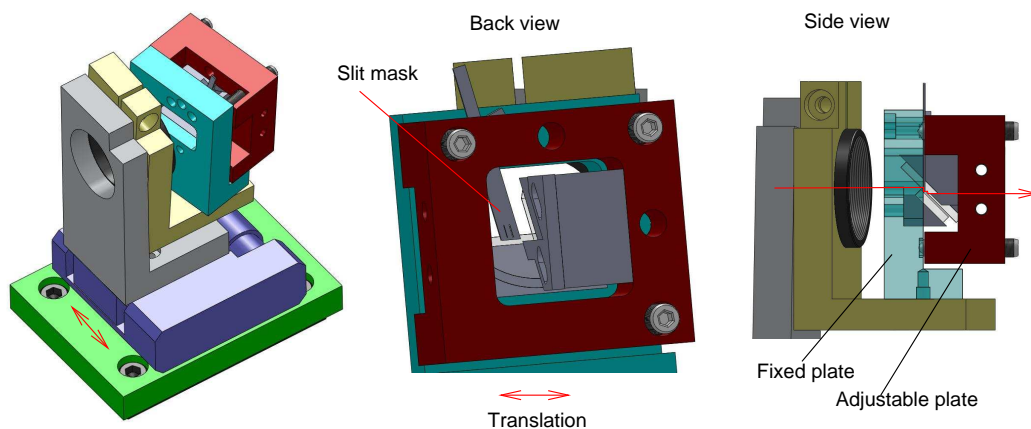

Figure 11: Mechanical design of the image slicer.

CHIRON uses a Bowen-Walraven image slicer. For fabrication reasons, two mirrors replace the standard design with total internal reflection (Fig. 10). The incident beam falls on the mirror M1 with a sharp edge AA', passing near the edge BB' of another mirror M2. Part of the beam passes directly and forms slice #1. The remaining part is reflected upwards to the mirror M2 (which is parallel to M1), then back to M1. Again, part of the beam passes near the edge (slice #2). The rest bounces once more between the mirrors and forms the slice #3.

To reduce defocus, the beam is transformed to a slow $F/41$ ratio. The fiber image is magnified 8.3 times, to $a = 0.0825$ mm diameter. The gap thickness is then $h = a/\sqrt{2} = 0.58$ mm. The defocus of each slice $l_1 = 0.6$ mm causes a blur of $0.6/41=0.015$ mm, negligible even after 2 bounces. The sliced slit image is 0.27×2.4 mm size.

The image slicer is mounted on a linear translation stage (M-110.1DG from Physik Instrumente) with travel range 5 mm. Un-sliced fiber can be used by simply moving the slicing edge away from the image. Further motion occults the fiber by a mask with two slits (width 0.2mm and 0.1mm, height 2mm for both slits). By selecting normal or narrow slit, we can take spectra with narrow (un-sliced) orders but high resolution, at a cost of the light loss (Fig. 10).

3.5 Fore-Optics Box (FOB) and viewer

Table 3: Image relay optics in FOB (optical design)

| Element | Part number (EO) | Dist. next, mm |
|----------------------------------|------------------|----------------|
| Fiber in FC connector | none | 15.72 |
| Lens L1, $F = 15$, $D = 6.25$ | N47-691 | 90 |
| Image slicer | Custom | 95.92 |
| Lens L2, $F = 100$, $D = 25$ | N47-671 | 210 |
| Diagonal mirror, 12.5mm | N45-754 | 10 |
| Lens L3, $F = 12.5$, $D = 6.25$ | N47-690 | 10.36 |
| Collimator focus | none | 609.6 |

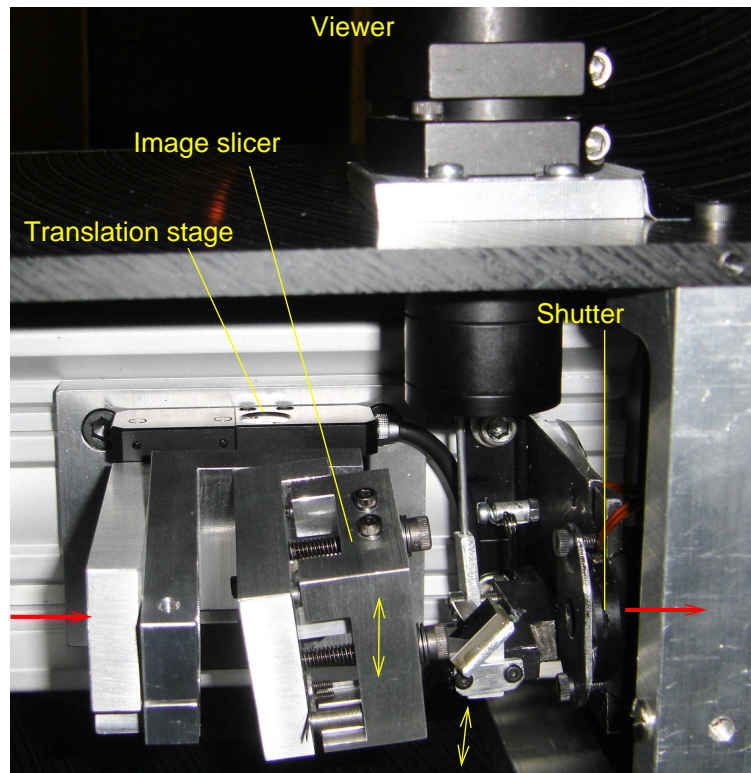

Figure 12: Image slicer and viewer. Red arrows show the light path from fiber to the spectrometer.

Table 3 contains the optical elements of the image relay as designed, from fiber to collimator. The beam emerging from L2 is collimated; it can go through the iodine cell without focus re-adjustment. The beam diameter is 3 mm for each image point, or 5.5 mm considering all points with a slicer.

The slit can be viewed by intercepting the beam with a small 15x20mm flip mirror. The beam is reflected in the viewer tube. Two achromatic lenses re-image it on either a CCD camera (used for alignment not part of CHIRON) or an eyepiece.

3.6 Iodine cell

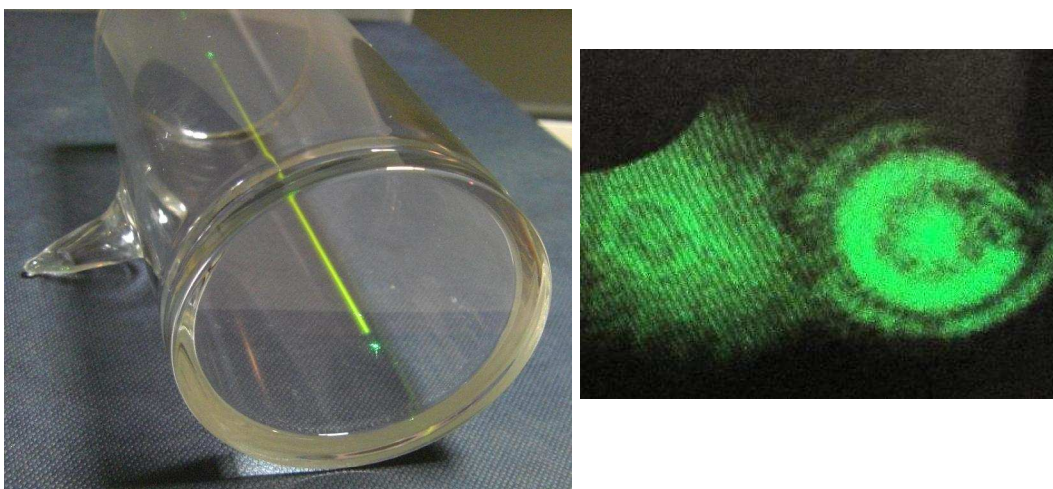

Figure 13: Iodine cell. The green laser beam is visible inside the cell because it is absorbed and scattered by iodine molecules. Picture on the right shows fringes from two cell windows in reflected light. They are centered for one window (circles), while the other window is tilted and gives high-frequency fringes.

The iodine cell is used to imprint narrow absorption lines in the stellar spectrum for precise wavelength reference. It is a sealed glass container (diam. 50 mm, length ~ 100 mm) filled with iodine vapor (Fig. 13). The cell is maintained at temperature of $+40^{\circ}\text{C}$ to keep all iodine vaporized.

In CHIRON, the cell is placed in the narrow parallel beam after L2. Its windows must be of good optical quality, otherwise their aberrations would distort the PSF. Similarly, the combined wedge should be small, otherwise the cell displaces the spectrum. Moreover, the windows produce interference which creates a weak sinusoidal modulation in the transmitted spectrum. In the V-1 cell currently in use, the 6-mm windows are slightly tilted (by the glass-welding procedure) which averages out the fringes. Fringing depends on the cell orientation.

3.7 Exposure-meter feed

About 1% of light is derected to the exposure meter (EM) by optical fiber. The light is taken from the collimated beam before it reaches the grating (Fig. 14). Originally, the 15-mm central part was reflected back by a corcular mirror with a hole. However, the beam center is “dark” because of the

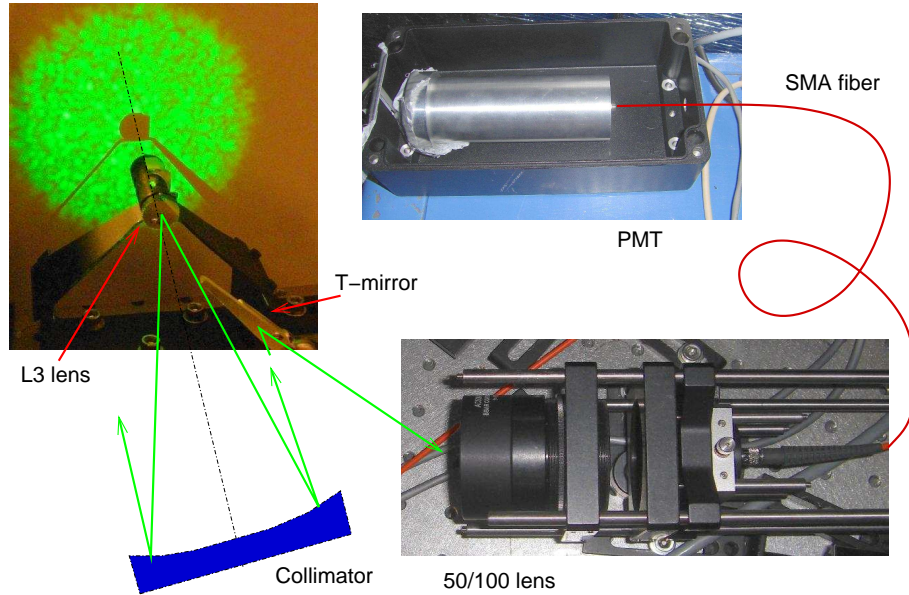

Figure 14: Optical elements feeding 1% of light to the exposure meter.

central obstruction in the telescope (the FRD of the fiber is small enough to preserve this obstruction in the outgoing beam). Therefore, in 2012 the circular mirror was replaced by a triangular mirror (T-mirror) in front of the vane that supports the CFA. In this way, the EM samples the beam correctly. The base of the T-mirror is 5-mm wide, its length is 50 mm.

Portion of the parallel beam reflected by the T-mirror is focused by a lens ($D = 50$ mm, $F = 100$ mm) on the SMA fiber with 200- μ m core. The position of the T-mirror and its angle are adjusted to coincide with the vane shadow and to direct the beam into the lens. The tilts and focus of the lens+fiber module are adjusted by shining the red light into the SMA fiber and making its image to coincide with the slicer.

The SMA fiber delivers light to the photo-multiplier (PMT), model H9319-11 from Hamamatsu. A filter of 545/90 nm is installed in front of the PMT to measure flux in the “iodine” region of the spectrum. The PMT counts are accumulated with 0.1 s time cadence and transmitted to the EM computer through serial interface.

3.8 Optical transmission

The optical transmission of the spectrograph (from L1 to field flattener) at 545 nm (measured in February 2012) is 60% in fiber mode and 52% in slicer mode.

4 Mechanical design of CHIRON

CHIRON consists of the following main sub-systems (Fig. 15):

- **Optical support structure** (OSS) holds together all optical elements in fixed relative position. The OSS consists of the standard optical table 90x75x11 cm and a rigid frame attached to it. The table is oriented horizontally.
- **Instrument support structure** (ISS) is an interface between the OSS and the external world. ISS interfaces to the enclosure (and is part of it). ISS holds the CCD dewar with field flattener.
- **Enclosure** protects CHIRON from light and dust. The environment inside the enclosure is stabilized in temperature.
- **Optical mounts** hold CHIRON elements such as echelle, collimator, collimator focal assembly (CFA), prism, triplet, fold mirror. All mounts are attached to the OSS.
- **Fore-optics box** (FOB) contains optical elements preceding the CFA: fiber connector, lens L1, image slicer, shutter. A flip mirror can be inserted manually to view the beam after the image slicer.

4.1 ISS and OSS

The ISS (Fig. 15) is a steel frame structure. It consists of two welded modules bolted together. The vertical frame is welded from the U-channel steel profile (2"x1", wall thickness 3/16"), the lower (horizontal) frame – from the 3"x3" square profile (wall thickness 1/8"). Two diagonals connect these parts in a stiff way.

The horizontal frame transmits the weight load to the ground through three stationary supports (when installed definitively) or through 4 wheels (during integration and transport). The OSS (optical table) attaches to the vertical frame at two points A and B, while its other end is supported by a vertical screw at point C, connected to the table at two points by a horizontal beam. The point A is close to the dewar, minimizing the image displacement on the detector caused by possible deformations of the ISS. Flexure of the ISS must not be transmitted to the OSS. Ideally, an un-constrained kinematic connection between the table and the ISS requires that the point A be fixed in all 3 coordinates XYZ, point B – in X and Z only, point C – in Z only. The actual system as designed constraints the connection at B in all 3 directions.

The vertical frame holds the dewar assembly and has a rectangular opening for the echelle box. The variable weight of the dewar is supported by the ISS, not by the OSS.

The OSS is based on the standard optical table of 90x75x11 cm size (English hole pattern and threads, PBH 12111 from Thorlabs). The optical axis is at 100 mm height above the table. Most elements are attached to the table using its hole pattern and/or clamps.

A II-shaped structure, "bridge", is attached to the table. It is welded from the stainless-steel profile (U-channel) of 4"x2" cross-section, the wall thickness is 4.8 mm (3/16"). The two legs of the bridge are bolted to the table. Two diagonal members ensure bridge stiffness against bending moments. The bridge holds attachment elements for the echelle and for the fore-optics box (FOB) – the FOB plate. The latter connects to the OSS through the box-shaped structure bolted to the bridge.

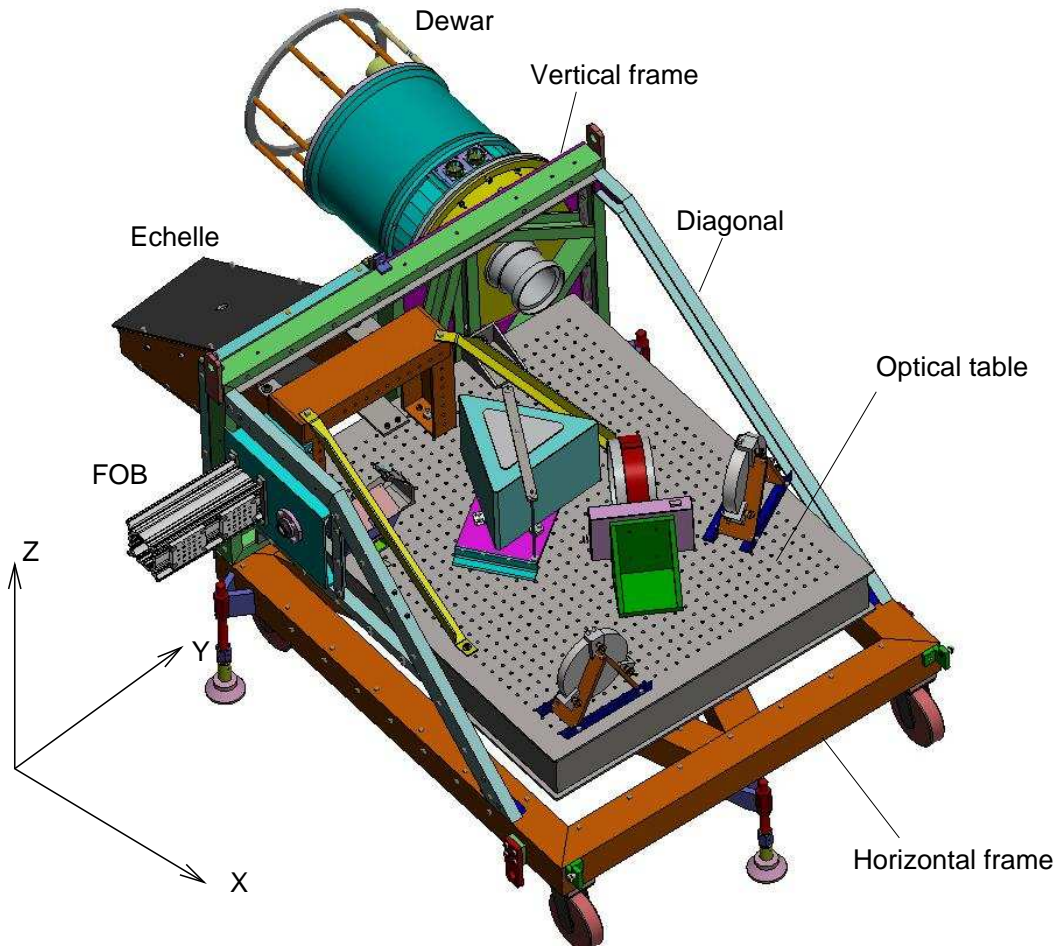

Figure 15: Overall CHIRON structure. The new vacuum echelle enclosure is not shown.

4.2 Enclosure

The CHIRON enclosure consists of three parts (Fig. 17): an isolated part of the ISS (E1), a big box covering the table (E2), and a smaller box covering the echelle (E3). The three parts join by means of a foam seal, making an air-tight container. The size of E2 is 980x900x480 mm, the size of E1 is 500x450x400 mm.

The boxes are made of 1.6-mm aluminum sheet attached to the frame welded from aluminum profile. The frame has a smooth and rigid contact surface along the edge of the box. When the box is closed, it presses against bulb silicone seal¹, compressed to the 6-mm thickness. The box itself is hermetized with aluminized duct tape and silicone.

From the outside, the boxes are covered by a 1" thermo-insulating foam panels made from polyisocyanurate. The foam is enclosed between thin metal foil on both sides, the cut edges are sealed with the duct tape. These panels can be easily detached from the box. The same panels surround the

¹part No. 91241K921 from mcmaster.com

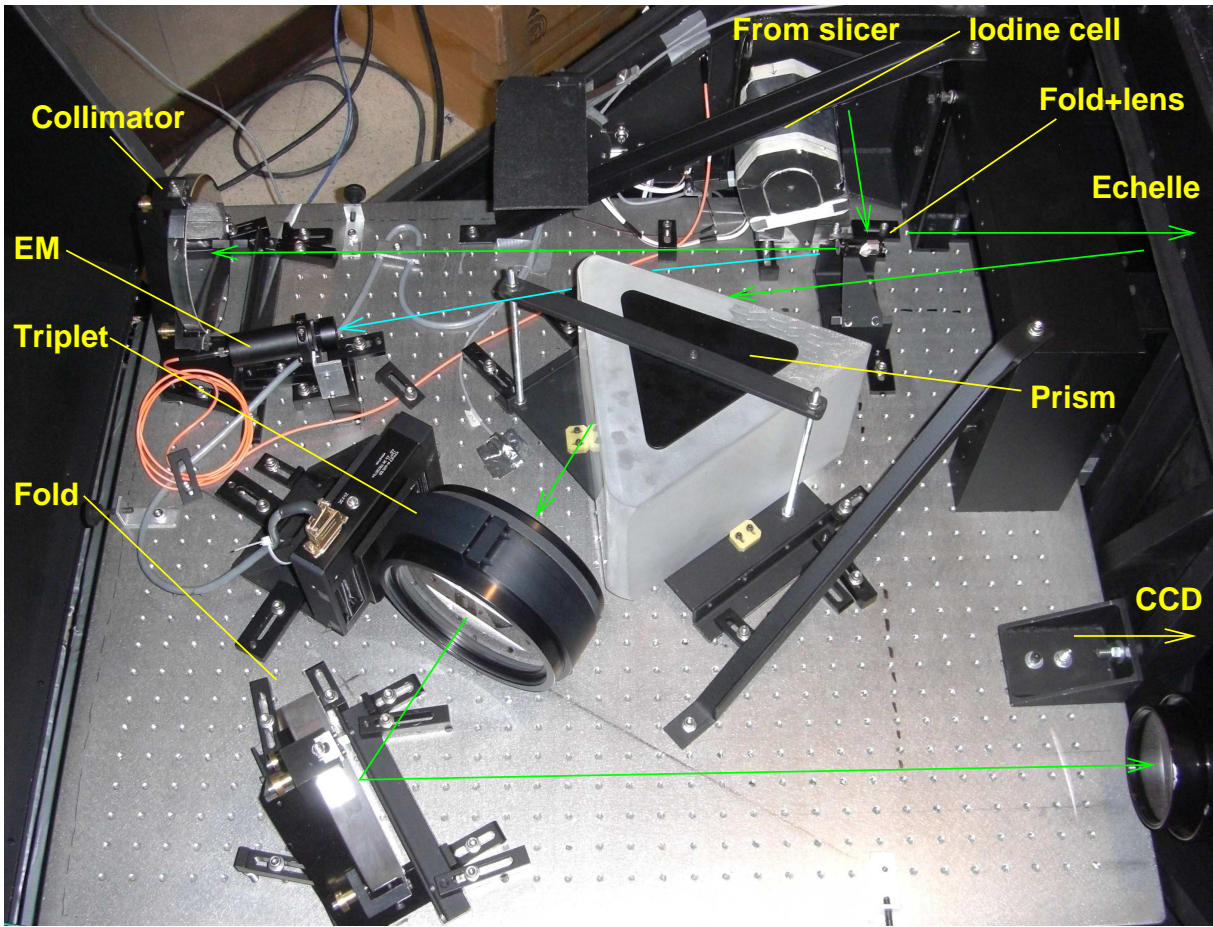

Figure 16: Picture of the CHIRON optical table. The main light path is traced by the green lines, the EM beam is light-blue.

fixed enclosure part E1 and the non-hermetic box around the FOB, not shown in Fig. 17.

The rectangular gap between the plate which holds the FOB and the E1 wall is sealed with foam and duct tape. The FOB space is not hermetized, the light goes inside CHIRON through the lens L2 which acts as a seal. The exit port (towards the CCD) is hermetized by the field-flattener lenses, dewar base and the plastic wall. Aluminum panels close the E1 on both sides below the diagonals and below the table. Electrical connectors are located on the triangular E1 panel near the FOB.

The box E2 is attached to the ISS by two hinges along its lower edge, so that it can be conveniently opened. The hinges can be disconnected for a complete removal of E2, if needed. The E3 is simply pressed with 4 screws near its corners.

The lower aluminum panel of E1 is heated by three silicone heating strips [45W, 1"x18", part No. 35765K254 frpm mcmaster.com] glued to it. The heater is controlled to stabilize the CHIRON internal temperature.

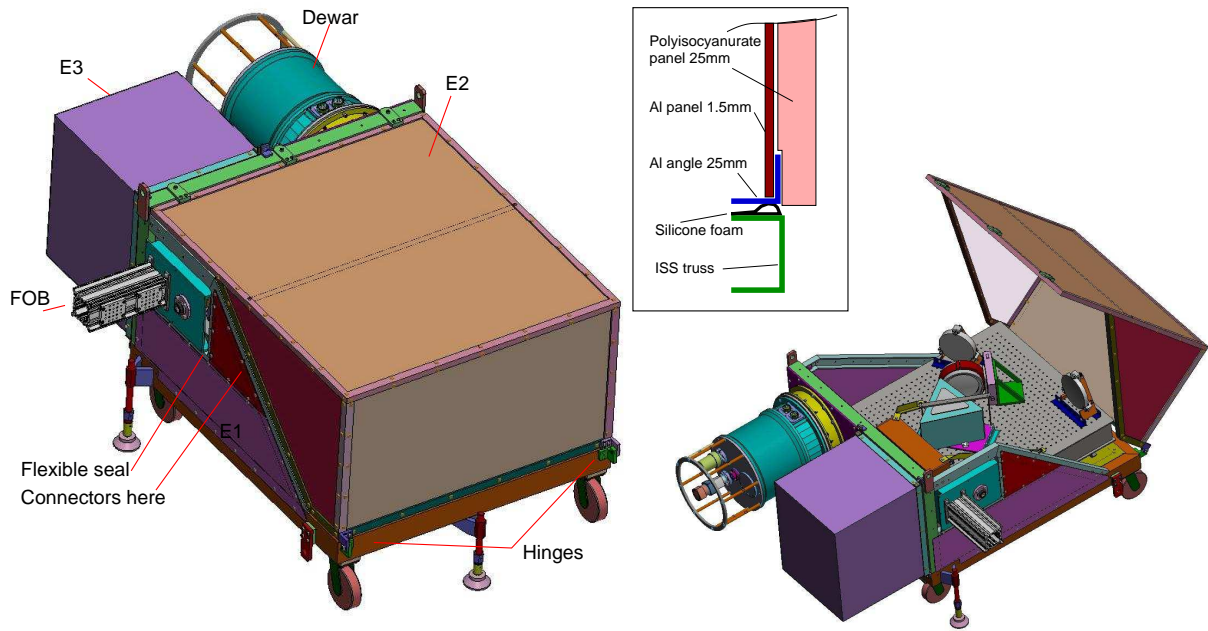

Figure 17: The enclosure. The scheme shows the air-tight interface to the ISS in cross-section, the picture on the right shows the opened enclosure.

4.3 Dewar attachment

The CCD dewar is a cylinder of 312 mm diameter and a slightly larger length. The mounting flange has outer diameter 360 mm, the CCD surface is 9.32 mm behind it, with a 9-mm fused-silica window, AR-coated. The back side of the dewar is protected by a ring, making the whole dewar length equal to 510 mm. The LN₂ tank volume is 5.41.

The dewar mount consists of two main pieces (Fig. 18): the base (gray) attached to the ISS and the flange (yellow) to which the dewar (blue) is bolted. The flange can be adjusted w.r.t. base in tilts and roll angle, then firmly fixed.

The base has outer diameter of 380 mm. It is pressed to the plastic plate (1/4", black delrin, green color in Fig. 18) which connects it with the ISS with several screws. The plastic provides thermal and electric insulation of the dewar from the ISS. Slightly over-sized holes allow small lateral adjustment during the assembly. The union is hermetized with black silicone. Therefore, the plastic plate seals the inner space of CHIRON from air and light. Differential thermal expansion between the steel ISS and the aluminum base is expected; the resulting stress will be alleviated by the plastic between these elements.

The dewar flange fits inside the base, centered by a thin "collar" with matched diameter and an O-ring near it. This allows for tilts and rotation (roll). Once the adjustment is done, the two parts are pressed together by 8 clumping plates, as shown in the cross-section (both parts are slightly deformed by clamping, removing residual gaps). Initially, the clamps are free. The tilts of the flange are regulated by means of 3 push and two pull screws, the roll – by an adjuster at the side of the cylinders. The dewar can be removed and installed without perturbing the tilt/roll adjustment.

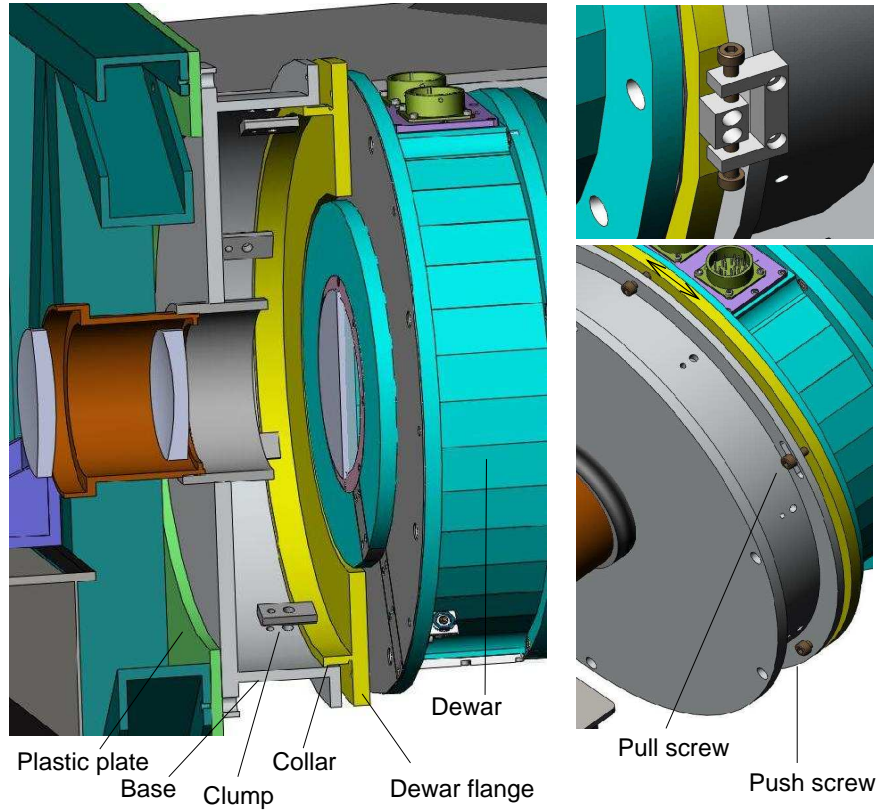

Figure 18: Dewar alignment.

The field flattener is screwed into a 100-mm cylinder which, in turn, is screwed into the base. This allows for an air-tight connection and provides for some axial adjustment of the field flattener. The space between the base and the dewar flange is almost sealed, a small container with desiccant is placed there to prevent dew condensation on the dewar window.

4.4 APO mount and focusing

The APO-140 triplet is mounted in a steel cylinder of 168 mm diameter (with 172-mm outer rim) and 76 mm length. The edge of the front lens is at a depth of ≈ 16 mm w.r.t. the front edge of the cylinder. The back end of the cylinder has an internal thread. The design of the APO-140 mount is shown in Fig. 19. For focusing, the triplet can be moved axially under remote control, using a commercial translation stage M-605.1DD from Physik Instrumente. The translation range is 25 mm. The stage has a load capacity of 20 kg axial and 10 kg lateral. The resolution is $0.1 \mu\text{m}$, accuracy $1 \mu\text{m}$, pitch and yaw stability $\pm 30 \mu\text{rad}$. Considering that the optical axis is at ~ 100 mm from the stage, the latter number translates to $\pm 3 \mu\text{m}$ lateral shifts, or $1/5$ of the CCD pixel. The APO steel cylinder is clamped by a split ring which is bolted to the stage, with a thin interface plate in-between. The stage, in turn, is mounted on the table by means of a bracket.

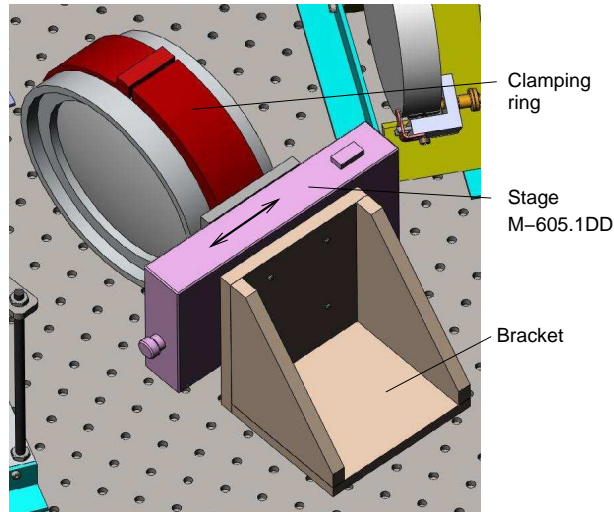

Figure 19: APO mount on the table, focusing.

4.5 Prism mount

The prism is big and massive. Sides 260 mm (around apex) and ~ 275 mm (base), height 160 mm, estimated mass 10 kg. Considering that the glass homogeneity on one side of the blank is not good, the beam center should be at 75-mm height above the good side, leaving 80 mm distance to the other (bad) side.

The prism rests on three plastic pads glued to the 8-mm thick base plate of 270x160 mm size. Lateral position of the prism is defined by three adjustable thick plastic stops which press against polished sides without vignetting the beam. The prism is pressed against the plate by the upper triangular plate with 3 plastic pads and the steel bar screwed to the base-plate with two long rods. The elasticity of the bar and triangular plate provide adjustable clamping force.

The base plate is attached to the table with two steel angles. The angle of the prism (in cross-dispersion direction) and its position are adjustable by moving the mount on the table, then clamping it. The prism position is “memorized” by 3 adjustable stops on the table, permitting to dismount and re-install it reproducibly.

4.6 Echelle enclosure

During CHIRON upgrade in 2012, the echelle grating was changed. It was mounted in a vacuum enclosure to prevent spectrum shifts caused by atmospheric pressure variations. The enclosure container (Fig. 20) is machined from a solid aluminum piece. On the front side, the entrance window is mounted, hermetized by a Viton O-ring. The window has diameter 210 mm, it is cut to 150 mm on two sides. The glass has a 1.5° wedge in the long (cross-dispersion) direction, its thickest part is 25 mm. The front surface of the window is perpendicular to the beam, the back (vacuum) surface is tilted by 1.5° . The top plate (again with O-ring) can be removed to mount the echelle cell. The plate also holds a round hatch for servicing vacuum (valve and sensor).

The echelle grating blank (Zerodur) has size 135x265x45mm. It is mounted in its cell kinematically,

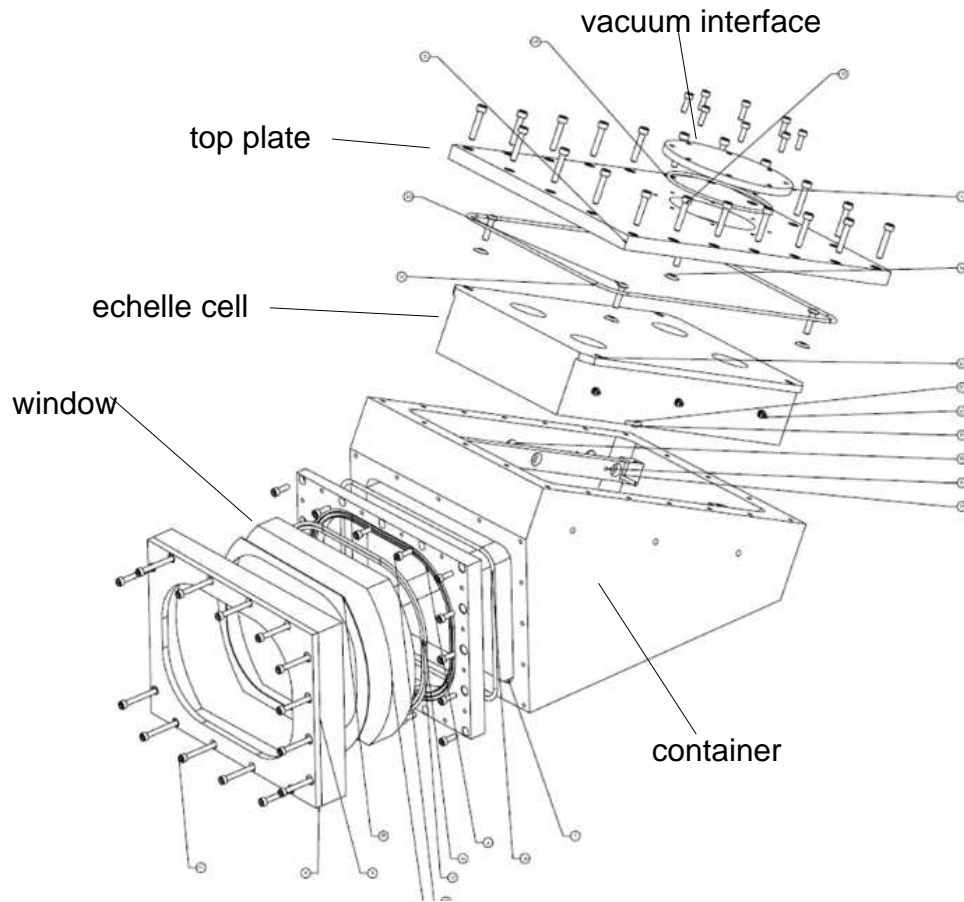

Figure 20: Echelle enclosure assembly.

face down. The angle is defined by three hard pads with plastic surface that press against the ruled surface. Each hard point has a spring load opposite to it.

The echelle enclosure is bolted to the aluminum “box” in such way that it is adjustable in tilt (β). The box connects to the OSS by means of two 6-mm steel plates bolted to the table and two steel angles bolted to the bridge. To adjust the echelle angle in the γ -direction (cross-dispersion), the box is rotated in the horizontal plane, using two screws as an axis. The other pair of screws passes through elongated holes. The pivot point of the γ -tilt is at a distance of ~ 30 cm from the grating center, so the adjustment causes acceptably small lateral motion of the beam on the grating (5 mm per 1°). The angles γ and β remain fixed during CHIRON operation.

The vacuum in the enclosure is degrading with time due to outgassing. It is deemed that maximum admissible pressure is 8 mB (1% of atmospheric pressure). For periodic pumping of the echelle, an access door in E3 is provided (Fig. 21). The vacuum interface consists of a T piece welded to a stainless steel interface plate. One side has a manual valve and a 3-ft long corrugated steel tube. The flanges are K25 standard. The vacuum is measured with a thermocouple gauge.

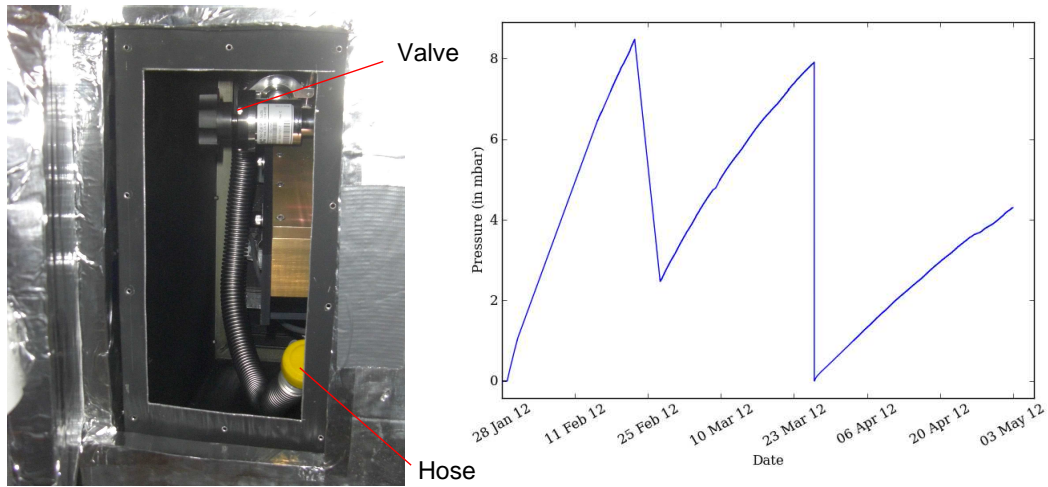

Figure 21: Acces door in the E3 enclosure for pumping echelle enclosure (left) and pressure inside the enclosure (in mB) vs. time (right).

4.7 Collimator focus assembly (CFA)

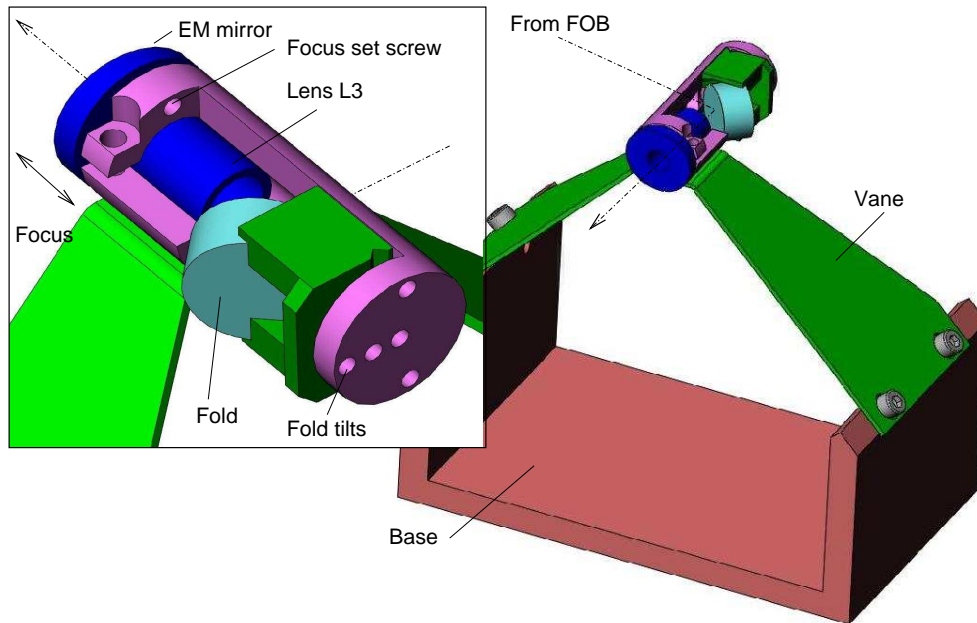

Figure 22: Collimator focus assembly.

The CFA module includes a small (12.7-mm) mirror to turn the beam by 90°, a focusing lens L3 ($F = 12.5$ mm, $D = 6.25$ mm), and a flat mirror with a 1.5-mm hole. This latter mirror intercepts the central part of the collimated beam (which would be obscured anyway) and sends it back to the

exposure-meter. All three elements are assembled in a unit with a small footprint (to reduce the beam obstruction) and suspended at the center of the collimated beam. The design (Fig. 22) implements this with two steel vanes (thickness 1 mm) at 40° from the vertical. The vanes are fixed to the base (U-channel steel profile 4" x 2") which, in turn, is clamped to the table. The vanes are made of a single plied steel sheet, its central part is bolted to the circular body of 15 mm diam. During assembly, the central body and the base are fixed at correct position (100 mm above the table, parallel) while the vanes are not yet attached. Then the lower ends of the vanes are fixed (the holes in the vanes are elongated).

The lens L3 is glued in a barrel of 8 mm diameter which slides axially inside a matching channel for focusing in the range ± 1 mm (pressed against a set screw), then clamped. It is easy to remove and put back the L3 barrel. The front surface of the barrel is machined at 5.5° angle to its axis. A thin mirror with a hole at the center is glued to this surface to reflect the light for the exposure-meter. The reflection angle is fixed, but its azimuth can be regulated by rotating the barrel.

The folding mirror (12.7 mm diameter, 6 mm thickness) is glued in a steel holder which can be adjusted in tilts by means of three set screws and one pulling screw (the screws are not shown in Fig. 22). The adjustment screws are easily accessible. Note that the mirror is excessively thick, its protruding part which increases the footprint is cut.

There is an on-axis hole in the back wall. Once the mirror is removed, this hole can serve for the initial alignment of the CFA body, using a thin laser beam to trace the axis. Then the mirror is installed and aligned to reflect the beam at correct angle and position.

4.8 Collimator and fold mounts

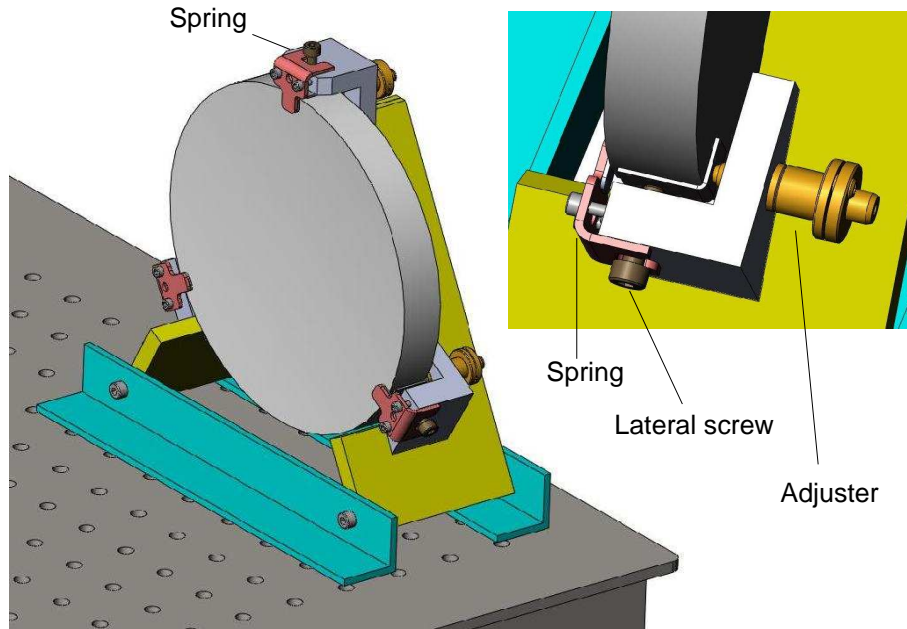

Figure 23: Design of the collimator and fold mounts.

The collimator mirror has diameter 152 mm, edge thickness 17.5 mm. The fold mirror is also 6" diameter, with 1" (25.4mm) edge (Edmund Optics, N48-125). The mounts for both elements are similar (Fig. 23). The optics is held by three right-angle units attached to the pair of aluminum ribs. The ribs are bolted to two steel angles which are clamped to the table. This design has low thermal stress.

The holding unit is detailed in the insert of Fig. 23. The most critical axial adjustment is provided by the commercial fine-pitch screw AJS100-02H (Newport) with clamp. The range is about ± 0.3 mm. The mirror is pressed axially by a leaf spring, with an adjustable force. The lateral position is defined by two standard M4 screws on the two lower units and by a spring in the upper unit.

A common problem of all mirror mounts is friction. Once the optical element displaces slightly, the spring pressure tries to bring it back in contact with the hard point, but the support friction in the perpendicular direction reduces the restoring force, causing hysteresis or even preventing the spring action. To avoid this, the hard points and springs could be "floating" in the perpendicular direction. A simpler method is to reduce the friction by putting a thin Teflon sheet between the glass and the hard points. We adopted this approach and placed pieces of steel foil between screws and glass. The leaf springs have small Teflon pads; in addition, they are not very stiff laterally and can "float".

4.9 Iodine cell and its container

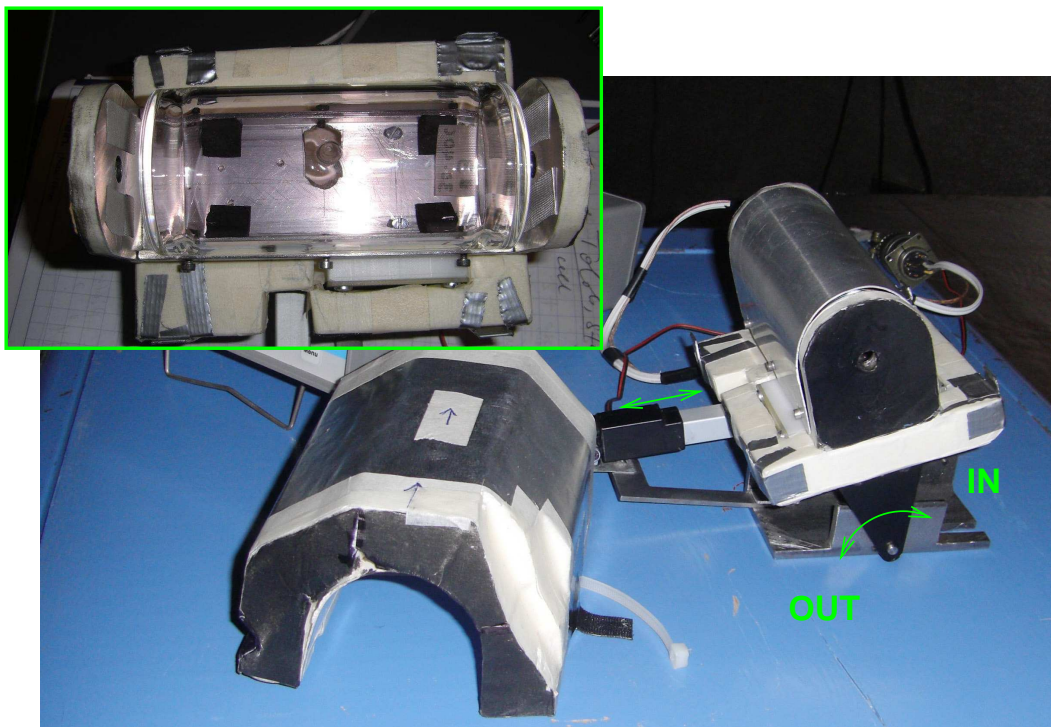

Figure 24: Photograph of the iodine cell container and its actuation mechanism. Part of the thermal insulation is removed. The insert shows opened container with a cell.

Iodine cells are glass cylinders of 40-50 mm diameter and maximum length 114 mm, with a small

“finger” on one side. The cell is maintained at uniform stabilized temperature (nominally $+40^{\circ}\text{C}$). It is placed in a heated aluminum box (Fig. 24). The heater element (Arcol power resistor, $1.2\text{ k}\Omega$, 10 W) and the $100\text{-}\Omega$ RTD temperature sensor are in thermal contact with the box and stabilize its temperature. The container is surrounded by thermal insulation (thickness $6\text{-}25\text{ mm}$), leaving only small (8 mm diameter) windows for passing the light. The length of the box with insulation along optical axis does not exceed 140 mm . The heating power is typically about 5 W .

The container is attached to the mechanism of its in-out motion by two fiberglass plates to minimize the heat conduction. The height and parallelism to the table are adjustable. The in-out mechanism consists of an axis oriented parallel to the beam and a linear actuator (Firgelli model L12-30-100-12-S). The axis rotates in a simple base (steel U-channel, $2''\times 1''$) clamped to the table. For servicing, the whole unit (including its electrical connector) should be removed from the CHIRON.

4.10 Hartmann mask

The Hartmann mask is used for checking the focus. It can cover upper or lower half of the collimator beam. The mask is operated manually, by inserting a hex key in the $1/4\ 20\ \text{TPI}$ screw protruding from the connector panel. The mask must be retracted after its use!